

GILMER COUNTY  
BRAXTON COUNTY

THIS AREA ASSESSED IN GILMER CO

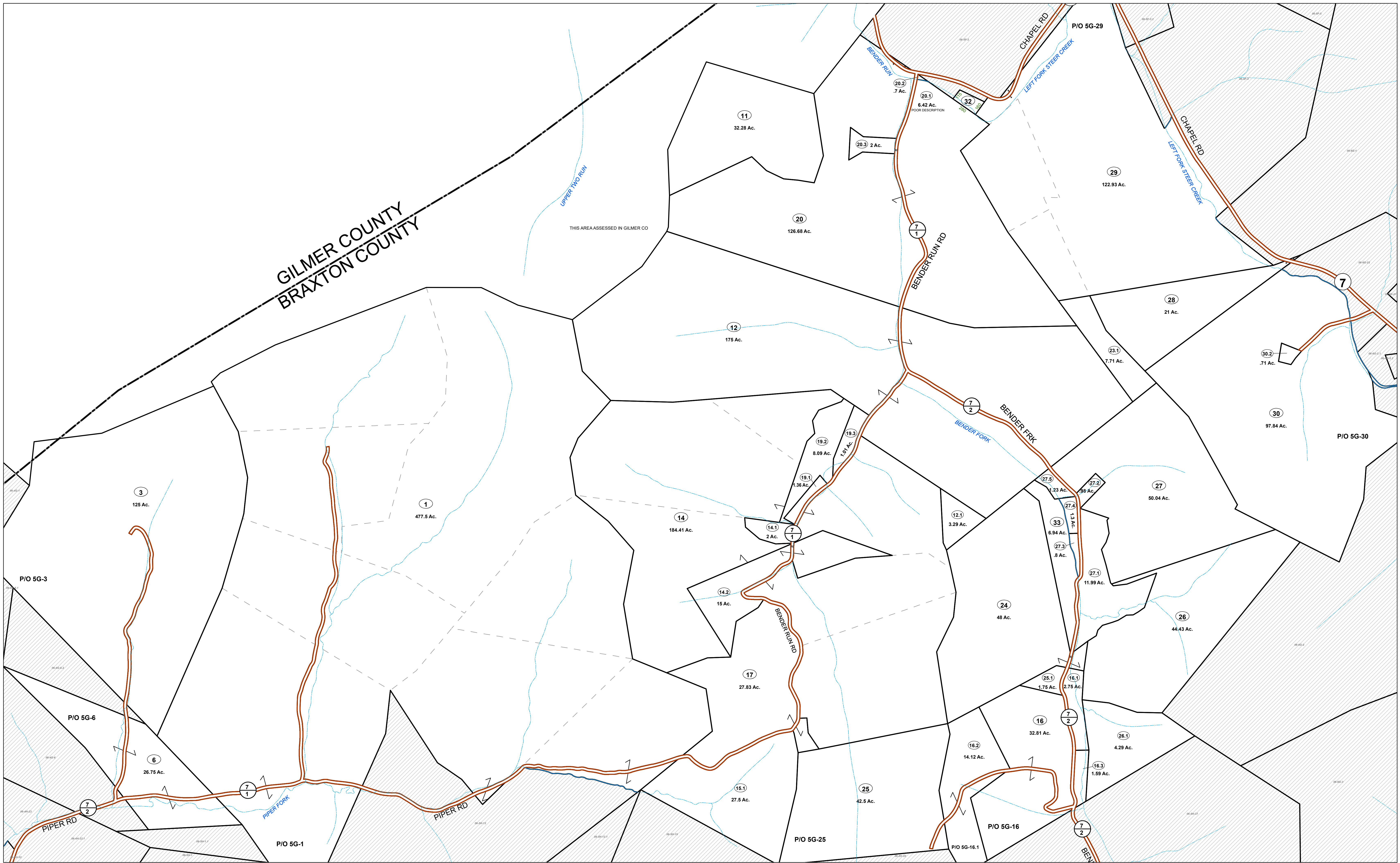

FOR TAX PURPOSES ONLY  
Prepared By:  
**Edith G Tichner**  
Braxton County Assessor

**Legend**

Property Line	Original Lot Line	Lot Number (15)
Road Right of Way	Parcel Number (99)	
Corporation Line	Water	
District Line	Railroad	
County Line		

R	1	Revised 09/2/2020	9		17
e	2	Revised 01/31/2022	10		18
v	3	Revised 09/13/2022	11		19
i	4	Revised 01/18/2023	12		20
s	5	Revised 07/20/2023	13		21
i	6	Revised 01/16/2024	14		22
o	7		15		23
n	8		16		24
s					

STATE OF WEST VIRGINIA  
COUNTY OF BRAXTON  
Office of Assessor

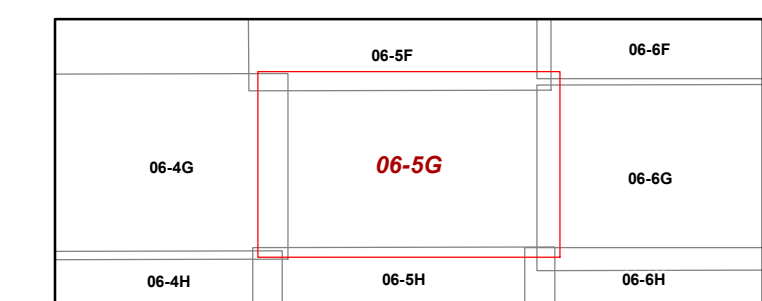

OTTER DISTRICT  
Map: 5G  
Date, Aerial Photography: 2019  
Date, Map: 1/16/2024  
Scale: 1 inch = 400 feet