

FOR TAX PURPOSES ONLY  
**LANDMARK**  
 geospatial  
*A Division of Landmark Forestry*

Legend	
	District Boundary
	Parcel or Index Number
	Previous Deed
	Property
	Road Easement
	Railroad Right of Way
	Road Right of Way
	River
	Cemetery
	Church
	Educational

**Restriction**  
 REPRODUCTION OF TAX MAPS PROHIBITED  
 - It is unlawful to copy, photograph, scan, or otherwise reproduce this tax map. Pursuant to the provisions of W.Va. CSR § 189-5-5 (2013) no person may reproduce, copy, distribute or sell copies of tax maps prepared by the counties without having first obtained the written permission of the Lewis County Assessor. In addition to other penalties and civil remedies, any person who, without the written permission of the Lewis County Assessor, reproduces, copies, distributes, or sells or who allows the reproduction, copying, distribution or sale of tax maps prepared by the Lewis County Assessor, shall be refused permission by the Lewis County Assessor or Assessor's agent to purchase tax maps in the future.

Revisions	
1	LANDMARK 1/1/2015 10
2	LANDMARK 6/1/2016 11
3	LANDMARK 6/1/2018 12
4	LANDMARK 1/1/2019 13
5	14
6	15
7	16
8	17
9	18
19	28
20	29
21	30
22	31
23	32
24	33
25	34
26	35
27	36

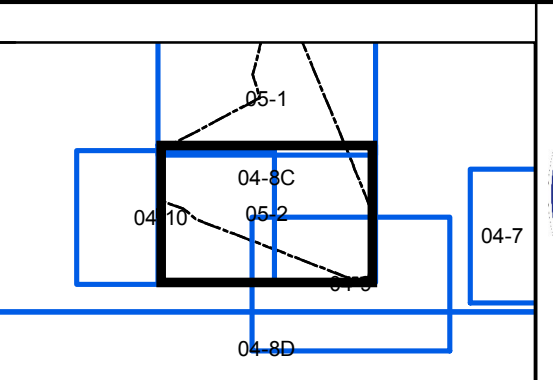

**LEWIS COUNTY**  
 Assessor's Office  
 John L. Breen, Assessor  
 WESTON, WV

**JANE LEW CORP**  
 District 05 Map No. 2  
 Date of Publication: 2/20/2019  
 Scale: 1" = 100'