

FOR TAX PURPOSES ONLY

PREPARED BY
RALEIGH COUNTY ASSESSOR'S OFFICE
 BECKLEY, WV

RESTRICTION

ALL TAX MAPS CREATED UNDER THE PROVISIONS OF REAPPRAISAL LEGISLATION ARE THE PROPERTY OF RALEIGH COUNTY, WEST VIRGINIA. THE REPRODUCTION, COPYING, DISTRIBUTION OR SALE OF SUCH TAX MAPS OR ANY COPIES THEREOF WITHOUT THE WRITTEN PERMISSION OF THE RALEIGH COUNTY ASSESSOR IS PROHIBITED BY LAW.

REVISIONS
1 12/04/97 SCR
2 03/31/98 SCR
3 09/25/01 CLG
4 07/16/09 TPB
5 11/10/15 KNH
6 09/01/16 BIE
7 04/06/17 KNH
8
9
10

TOWN DIST BECKLEY CORP		LEGEND	
---	CORPORATION/DISTRICT BOUNDARY AND NAME	---	7TH STREET
---	FAYETTE CO	---	RIGHT-OF-WAY
---	RALEIGH CO	---	PROPERTY LINE
---	01-17	---	ORIGINAL LOT LINE
---	01-36	---	DEED LOT NUMBER
---	ORIGINAL MAP BOUNDARY AND NUMBER	---	PARCEL OR INDEX NUMBER
---		---	2017 CHANGE
---		---	BLOCK NUMBER

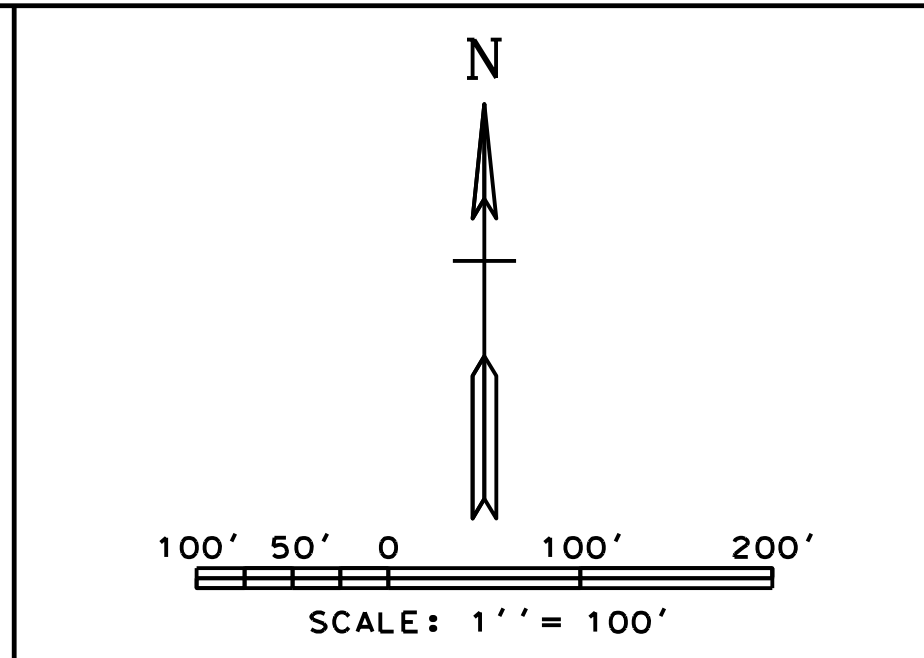

COUNTY OF RALEIGH
 OFFICE OF ASSESSOR
 BECKLEY, WEST VIRGINIA

BECKLEY CORPORATION
 DISTRICT 01
 MAP NO. 03