

FOR TAX PURPOSES ONLY

PREPARED BY
RALEIGH COUNTY ASSESSOR'S OFFICE
BECKLEY, WV

RESTRICTION

ALL TAX MAPS CREATED UNDER THE PROVISIONS OF APPRAISAL LEGISLATION ARE THE PROPERTY OF RALEIGH COUNTY, WEST VIRGINIA. THE REPRODUCTION, COPYING, DISTRIBUTION OR SALE OF SUCH TAX MAPS OR ANY COPIES THEREOF WITHOUT THE WRITTEN PERMISSION OF THE RALEIGH COUNTY ASSESSOR IS PROHIBITED BY LAW.

REVISIONS
1 05/05/98 CLG
2 02/08/99 CLG
3 04/13/00 CLG
4 06/13/01 CLG
5 11/21/02 CLG
6 05/22/06 CLG
7 08/27/10 TPB
8 05/09/14 BIE
9 08/06/15 BIE
10 01/26/16 KNH

TOWN DIST
BECKLEY CORP

FAYETTE CO
RALEIGH CO

01-17
01-36

LEGEND

7TH STREET RIGHT-OF-WAY

PROPERTY LINE

ORIGINAL LOT LINE

DEED LOT NUMBER

PARCEL OR INDEX NUMBER

2016 CHANGE

BLOCK NUMBER

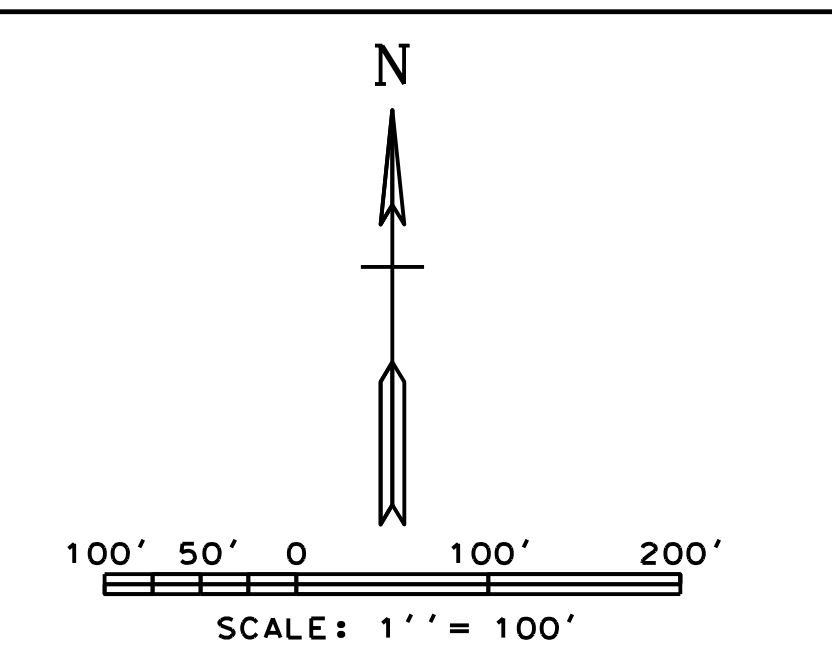

COUNTY OF RALEIGH
OFFICE OF ASSESSOR
BECKLEY, WEST VIRGINIA

BECKLEY CORPORATION
DISTRICT 01
MAP NO. 16