

FOR TAX PURPOSES ONLY

PREPARED BY
RALEIGH COUNTY ASSESSOR'S OFFICE
BECKLEY, WV

RESTRICTION

ALL TAX MAPS CREATED UNDER THE PROVISIONS OF REAPPRAISAL LEGISLATION ARE THE PROPERTY OF RALEIGH COUNTY, WEST VIRGINIA. THE REPRODUCTION, COPYING, DISTRIBUTION OR SALE OF SUCH TAX MAPS OR ANY COPIES THEREOF WITHOUT THE WRITTEN PERMISSION OF THE RALEIGH COUNTY ASSESSOR IS PROHIBITED BY LAW.

REVISIONS
1 06/24/97 CLG
2 05/07/98 CLG
3 04/24/00 CLG
4 12/16/05 CLG
5 01/26/09 TPB
6 04/07/09 TPB
7 08/08/11 TPB
8 MM/DD/YY ABC
9 MM/DD/YY ABC
10 MM/DD/YY ABC

TOWN DIST
BECKLEY CORP

FAYETTE CO
RALEIGH CO

01-17
01-36

CORPORATION/DISTRICT
BOUNDARY AND NAME

COUNTY BOUNDARY AND
NAME

ORIGINAL MAP BOUNDARY
AND NUMBER

LEGEND	
7TH STREET	RIGHT-OF-WAY
PROPERTY LINE	PROPERTY LINE
ORIGINAL LOT LINE	ORIGINAL LOT LINE
(9)	DEED LOT NUMBER
(38.0)	PARCEL OR INDEX NUMBER
(2)	BLOCK NUMBER
(1)	2011 CHANGE

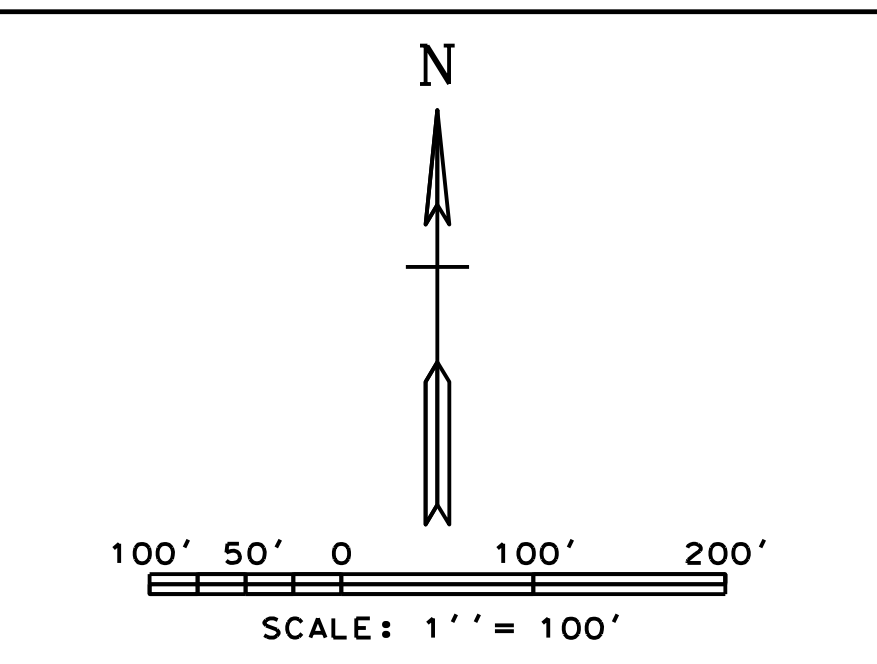

COUNTY OF RALEIGH
OFFICE OF ASSESSOR
BECKLEY, WEST VIRGINIA

BECKLEY CORPORATION
DISTRICT 01
MAP NO. 40