

FOR TAX PURPOSES ONLY

PREPARED BY
 RALEIGH COUNTY ASSESSOR'S OFFICE
 BECKLEY, WV

RESTRICTION

ALL TAX MAPS CREATED UNDER THE PROVISIONS OF REAPPRAISAL LEGISLATION ARE THE PROPERTY OF RALEIGH COUNTY, WEST VIRGINIA. THE REPRODUCTION, COPYING, DISTRIBUTION OR SALE OF SUCH TAX MAPS OR ANY COPIES THEREOF WITHOUT THE WRITTEN PERMISSION OF THE RALEIGH COUNTY ASSESSOR IS PROHIBITED BY LAW.

REVISIONS
1
2
3
4
5
6
7
8
9
10

LEGEND	
	TOWN DIST BECKLEY CORP CORPORATION/DISTRICT BOUNDARY AND NAME
	7TH STREET RIGHT-OF-WAY
	PROPERTY LINE
	ORIGINAL LOT LINE
	DEED LOT NUMBER
	PARCEL OR INDEX NUMBER
	2010 CHANGE
	BLOCK NUMBER
	FAYETTE CO RALEIGH CO COUNTY BOUNDARY AND NAME
	01-17 ORIGINAL MAP BOUNDARY AND NUMBER
	01-38 ORIGINAL MAP BOUNDARY AND NUMBER

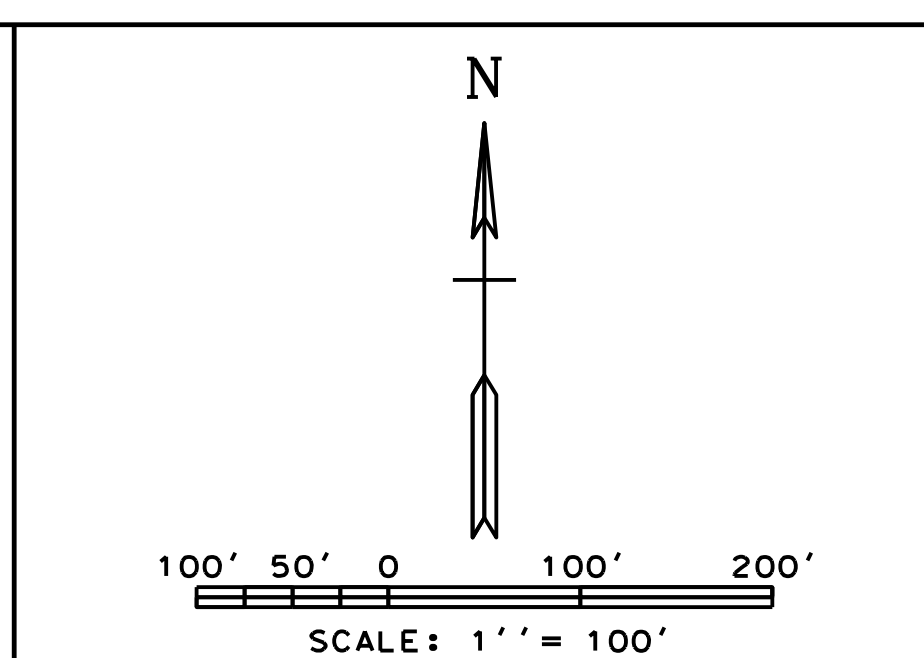

COUNTY OF RALEIGH
 OFFICE OF ASSESSOR
 BECKLEY, WEST VIRGINIA

BECKLEY CORPORATION
 DISTRICT 01
 MAP NO. 47