

FOR TAX PURPOSES ONLY

PREPARED BY  
**RALEIGH COUNTY ASSESSOR'S OFFICE**  
 BECKLEY, WV

---

**RESTRICTION**

ALL TAX MAPS CREATED UNDER THE PROVISIONS OF REAPPRAISAL LEGISLATION ARE THE PROPERTY OF RALEIGH COUNTY, WEST VIRGINIA. THE REPRODUCTION, COPYING, DISTRIBUTION OR SALE OF SUCH TAX MAPS OR ANY COPIES THEREOF WITHOUT THE WRITTEN PERMISSION OF THE RALEIGH COUNTY ASSESSOR IS PROHIBITED BY LAW.

REVISIONS	
1	07/22/96 CLG
2	12/02/97 CLG
3	11/17/99 CLG
4	12/13/02 CLG
5	02/28/03 CLG
6	
7	
8	
9	
10	

**TOWN DIST**  
 BECKLEY CORP

**FAYETTE CO**  
 RALEIGH CO

**01-17**  
**01-36**

CORPORATION/DISTRICT BOUNDARY AND NAME

COUNTY BOUNDARY AND NAME

ORIGINAL MAP BOUNDARY AND NUMBER

LEGEND	
	7TH STREET
	PROPERTY LINE
	ORIGINAL LOT LINE
	DEED LOT NUMBER
	PARCEL OR INDEX NUMBER
	2010 CHANGE
	BLOCK NUMBER

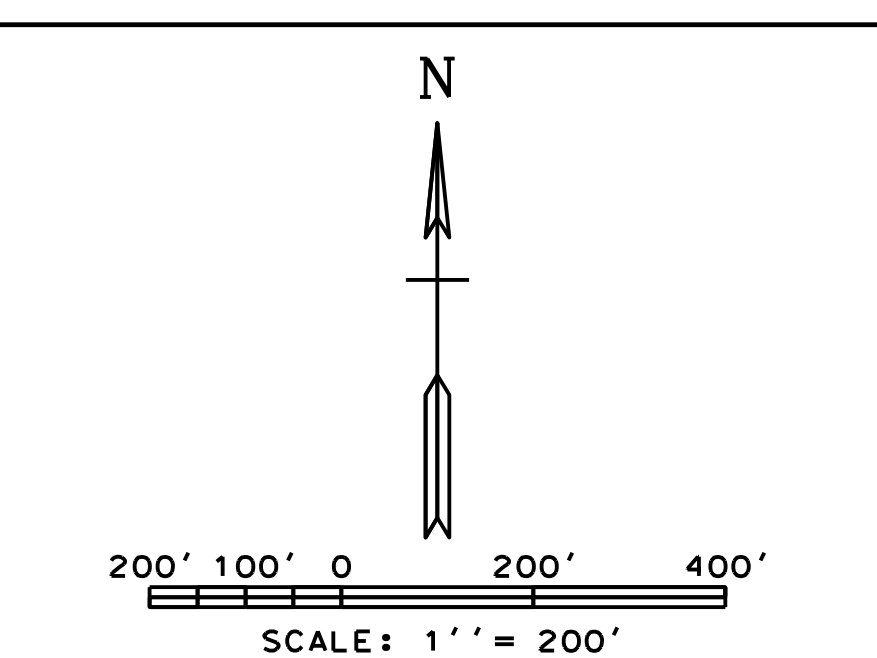

**COUNTY OF RALEIGH**  
**OFFICE OF ASSESSOR**  
**BECKLEY, WEST VIRGINIA**

**BECKLEY CORPORATION**  
**DISTRICT 01**  
**MAP NO. 49 (SE)**