

FOR TAX PURPOSES ONLY

PREPARED BY
RALEIGH COUNTY ASSESSOR'S OFFICE
 BECKLEY, WV

RESTRICTION

ALL TAX MAPS CREATED UNDER THE PROVISIONS OF REAPPRAISAL LEGISLATION ARE THE PROPERTY OF RALEIGH COUNTY, WEST VIRGINIA. THE REPRODUCTION, COPYING, DISTRIBUTION OR SALE OF SUCH TAX MAPS OR ANY COPIES THEREOF WITHOUT THE WRITTEN PERMISSION OF THE RALEIGH COUNTY ASSESSOR IS PROHIBITED BY LAW.

REVISIONS	
1	07/22/96 CLG
2	12/02/97 CLG
3	11/17/99 CLG
4	12/13/02 CLG
5	02/28/03 CLG
6	
7	
8	
9	
10	

TOWN DIST
BECKLEY CORP

FAYETTE CO

RALEIGH CO

01-17

01-36

LEGEND	
	RIGHT-OF-WAY
	PROPERTY LINE
	ORIGINAL LOT LINE
	DEED LOT NUMBER
	PARCEL OR INDEX NUMBER
	2010 CHANGE
	BLOCK NUMBER

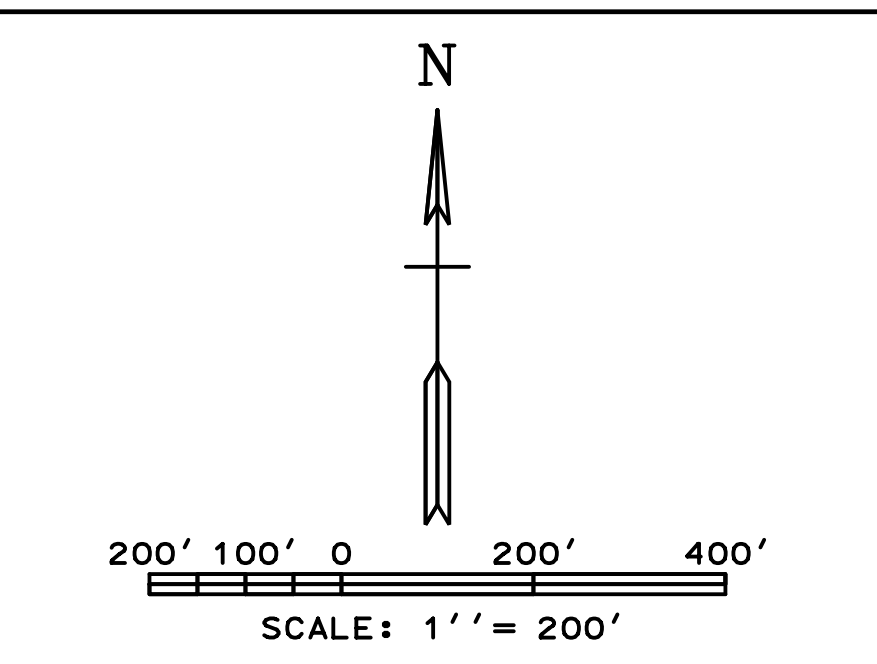

COUNTY OF RALEIGH
OFFICE OF ASSESSOR
BECKLEY, WEST VIRGINIA

BECKLEY CORPORATION
DISTRICT 01
MAP NO. 49 (SE)