



Legend	
	District Boundary
	Previous Deed
	Property
	Road Easement
	Railroad Right of Way
	Road Right of Way
	River
	Deed lot Number
	Parcel or Index Number
	UNKNOWN
	Improvement
	Cemetery
	School
	Church

Restriction

All tax maps created under the provisions of reappraisal legislation are the property of the Assessor of Randolph County, West Virginia and the reproduction, copying, modification, distribution or sale of such tax maps or any copies thereof without the written permission of the Randolph County Assessor is prohibited by law.

Revisions			
1	6-30-1964	10	OGIS D.S.H. 2-23-1991
2	D.F. 7-1980	11	OGIS T.L. 4-30-1992
3	T.R.L. 7-1983	12	OGIS J.E.B. 4-20-1995
4	C.P. 7-1-1983	13	OGIS J.E.B. 5-1-1996
5	C.P. 7-1-1984	14	SLS INC. J.W.M. 3-1997
6	N.C.S. 7-1-1985	15	P.K.Y. 7-1-1999
7	T.R.L. 7-1986	16	P.K.Y. 7-1-2000
8	D.F. 7-1-1988	17	P.K.Y. 7-1-2001
9	D.F. 7-1-1989	18	P.K.Y. 7-1-2003
19	A.K.B. 7-1-2006	28	
20	S.T.P. 7-1-2013	29	
21	S.T.P. 7-1-2014	30	
22		31	
23		32	
24		33	
25		34	
26		35	
27		36	

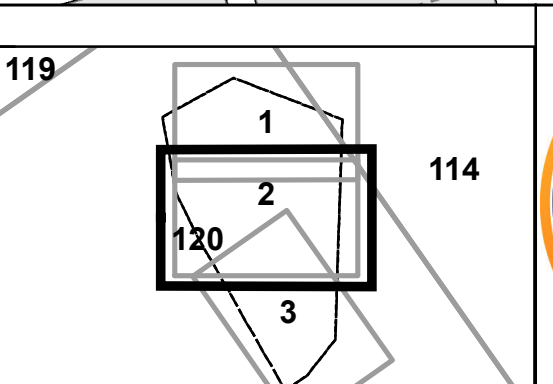

RANDOLPH COUNTY COALTON CORP
 Assessor's Office
 Phyllis K. Yokum, Assessor
 ELKINS, WV

District 03 Map No. 2
 Date of Publication: 1/18/2022
 Scale: 1"=100'