

FOR TAX PURPOSES ONLY
LANDMARK
geospatial

Legend	
	District Boundary
	Previous Deed
	Property
	Road Easement
	Railroad Right of Way
	Road Right of Way
	River
	Deed lot Number (15)
	Parcel or Index Number (9)
	UNKNOWN
	Improvement
	Cemetery
	School
	Church

Restriction

All tax maps created under the provisions of reappraisal legislation are the property of the Assessor of Randolph County, West Virginia and the reproduction, copying, modification, distribution or sale of such tax maps or any copies thereof without the written permission of the Randolph County Assessor is prohibited by law.

Revisions			
1	6-30-1964	10	OGIS T.L. 4-30-1992
2	D.F. 7-1-1980	11	OGIS S.A.J. 4-24-1993
3	C.P. 7-1-1983	12	OGIS R.R.O. 3-1994
4	T.R.L. 7-1-1984	13	OGIS J.E.B. 4-20-1995
5	N.C.S. 7-1-1984	14	OGIS J.E.B. 5-1-1996
6	T.R.L. 7-1-1986	15	SLS INC. J.W.M. 3-1997
7	D.F. 7-1-1988	16	P.K.Y. 7-1-1998
8	D.F. 7-1-1989	17	P.K.Y. 7-1-1999
9	OGIS D.S.H. 2-17-1991	18	P.K.Y. 7-1-2000
19	P.K.Y. 7-1-2003	28	
20	A.K.B. 7-1-2006	29	
21	A.K.B. 7-1-2008	30	
22	A.L.I. 7-1-2010	31	
23	A.S.T. 7-1-2011	32	
24	S.T.P. 7-1-2013	33	
25	S.T.P. 7-1-2015	34	
26		35	
27		36	

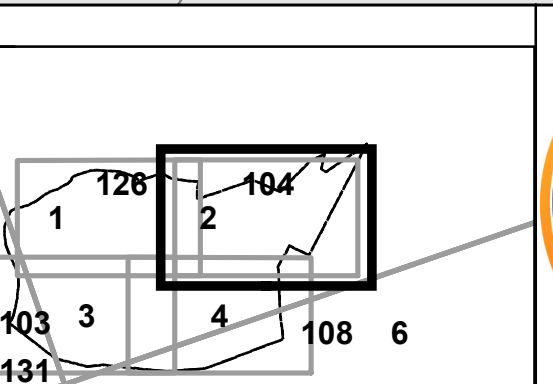

RANDOLPH COUNTY MILL CREEK CORP
 Assessor's Office
 Phyllis K. Yokum, Assessor
 ELKINS, WV

District 12 Map No. 2
 Date of Publication: 1/18/2022
 Scale: 1"=100'