

FOR TAX PURPOSES ONLY
LANDMARK
 geospatial

Legend	
	District Boundary
	Previous Deed
	Property
	Road Easement
	Railroad Right of Way
	Road Right of Way
	River
	Deed lot Number (15)
	Parcel or Index Number
	UNKNOWN
	Improvement
	Cemetery
	School
	Church

Restriction

All tax maps created under the provisions of reappraisal legislation are the property of the Assessor of Randolph County, West Virginia and the reproduction, copying, modification, distribution or sale of such tax maps or any copies thereof without the written permission of the Randolph County Assessor is prohibited by law.

Revisions			
1	6-30-1964	10	OGIS J.E.B. 5-1-1996
2	D.F. 7-1980	11	SLS INC. J.W.M. 3-1997
3	D.F. 7-1-1983	12	P.K.Y. 7-1-1998
4	C.P. 7-1-1983	13	P.K.Y. 7-1-1999
5	D.F. 7-1-1988	14	P.K.Y. 7-1-2000
6	D.F. 7-1-1989	15	P.K.Y. 7-1-2001
7	OGIS D.S.H. 2-17-1991	16	P.K.Y. 7-1-2003
8	OGIS T.L. 4-30-1992	17	P.K.Y. 7-1-2004
9	OGIS J.E.B. 4-20-1994	18	A.K.B. 7-1-2005
19	A.K.B. 7-1-2006	28	
20	A.K.B. 7-1-2009	29	
21	S.T.P. 7-1-2012	30	
22	S.T.P. 5-18-2017	31	
23		32	
24		33	
25		34	
26		35	
27		36	

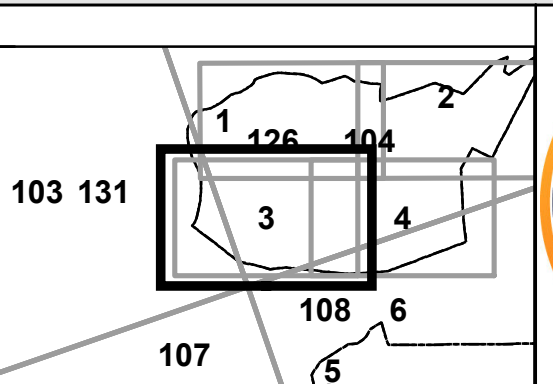

RANDOLPH COUNTY
 Assessor's Office
 Phyllis K. Yokum, Assessor
 ELKINS, WV

MILL CREEK CORP
 District 12 Map No. 3
 Date of Publication: 1/18/2022
 Scale: 1"=100'